



Sveabot[™] M100

RIDE-ON SMART FLOOR SCRUBBER



MAKING LARGE-AREA CLEANING EASIER

DESIGNED FOR LARGE-AREA CLEANING

Sveabot™ M100 has an unparalleled cleaning efficiency of 5590 m²/h and a maximum brushing pressure of 110kg. With humanized features like One-key U-turn and Cruise Control, large-area cleaning has never been made so easy before.



5590 m² / h

5590 m²/h
Cleaning Efficiency



15°
Gradeability
with Full Load



One-Key
U-Turn



Cruise Control

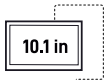

10.1"

Touchscreen

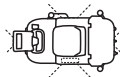

Full Coverage of
Blind Areas



Auto
Brake



Ergonomic
Design

EFFICIENT CLEANING



UP to 5590 m²/h Cleaning Efficiency | Up to 110kg Brushing Pressure | 3.5 Hours Runtime

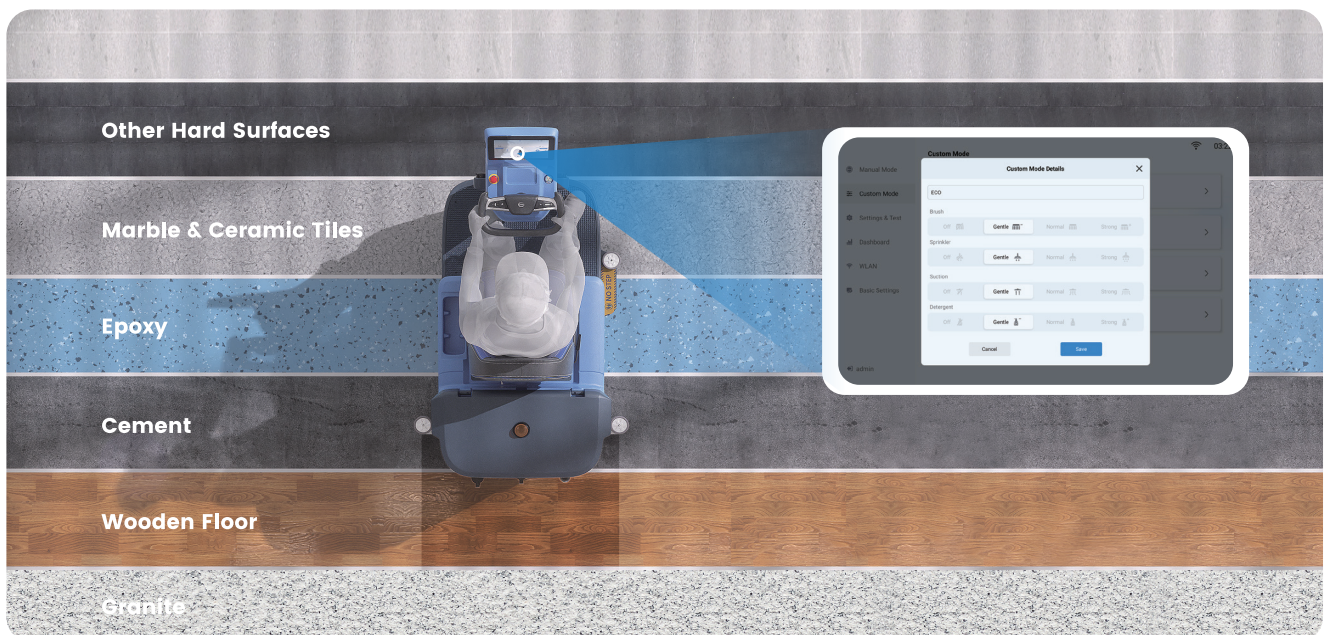

Adjust cleaning settings for different types of floor as needed

EASIER OPERATION



10.1" touchscreen for intuitive operation



Auto-generated cleaning reports with clear data

ULTIMATE DRIVING EXPERIENCE

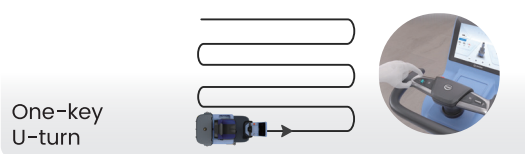

One-key U-turn



Cruise Control*

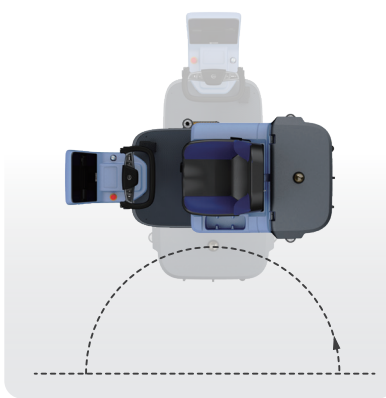

Compact Design & Zero Turn



15° (26%) Gradeability with Full Load

HIGHEST SAFETY STANDARD



Turning speed limit prevents rollover

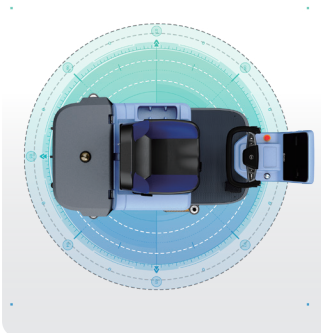

Full coverage of blind areas with real-time alert

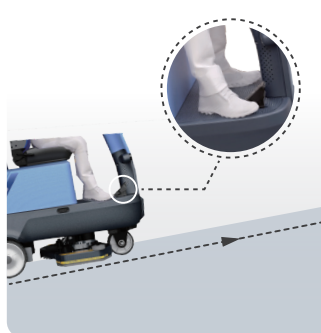

Climb slopes with auto hold

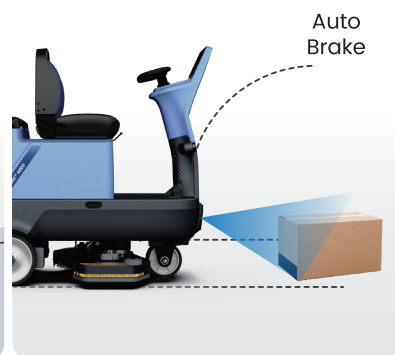

Auto brake when detecting obstacles in Safe Mode

*This feature doesn't guarantee self-driving in the product. Users must keep hands on the wheel and feet ready for braking, and follow the user's manual and manufacturer's instructions.

EXTENSIVE SCENARIOS



Parking Lot



Factory/Warehouse



Public Transport



Outdoor Space



Office Buildings



Supermarkets

SPECS

Model	Sveabot™ M100
Size	1600 * 940 * 1400 mm
Weight	284 kg
IP Rating	IPX3
Driving Mode	Two rear-wheel drive
Noise Level	< 80 dBA
Maximum Speed	6.5 km/h
Full Load Gradeability	15° (26%)
Minimum Turning Radius	1211 mm

Battery Specs

Battery Type	Lithium-ion
Charging Time	4 hrs
Battery Life	3.5 hrs
Battery Capacity	4000 Wh
Voltage	48 V

Disk Brush Specs

Type	Double disk brushes
Brush Speed	200 rpm
Brushing Pressure	60/90/110 kg
Diameter	406 mm
Cleaning Width	860 mm
Cleaning Efficiency	5590 m ² /h
Fresh Water Tank	120 L
Waste Water Tank	140 L
Detergent Tank	5 L

Others

Reverse Warning	✓
OTA Update	✓
Power-on Self-test	✓
Liquid Level Sensors	✓

Website: sveabot.com
 Tel: +1 833 242 9800
 Email: sales@sveabot.com



SVEABOT,
WITH HUMANIZED DESIGN FROM SCANDINAVIA

Copyright © Sveabot. All rights reserved.